

**WD01SS 14 cm Warming
Drawer**

**WD02SS 30 cm Warming
Drawer**

INSTRUCTION MANUAL

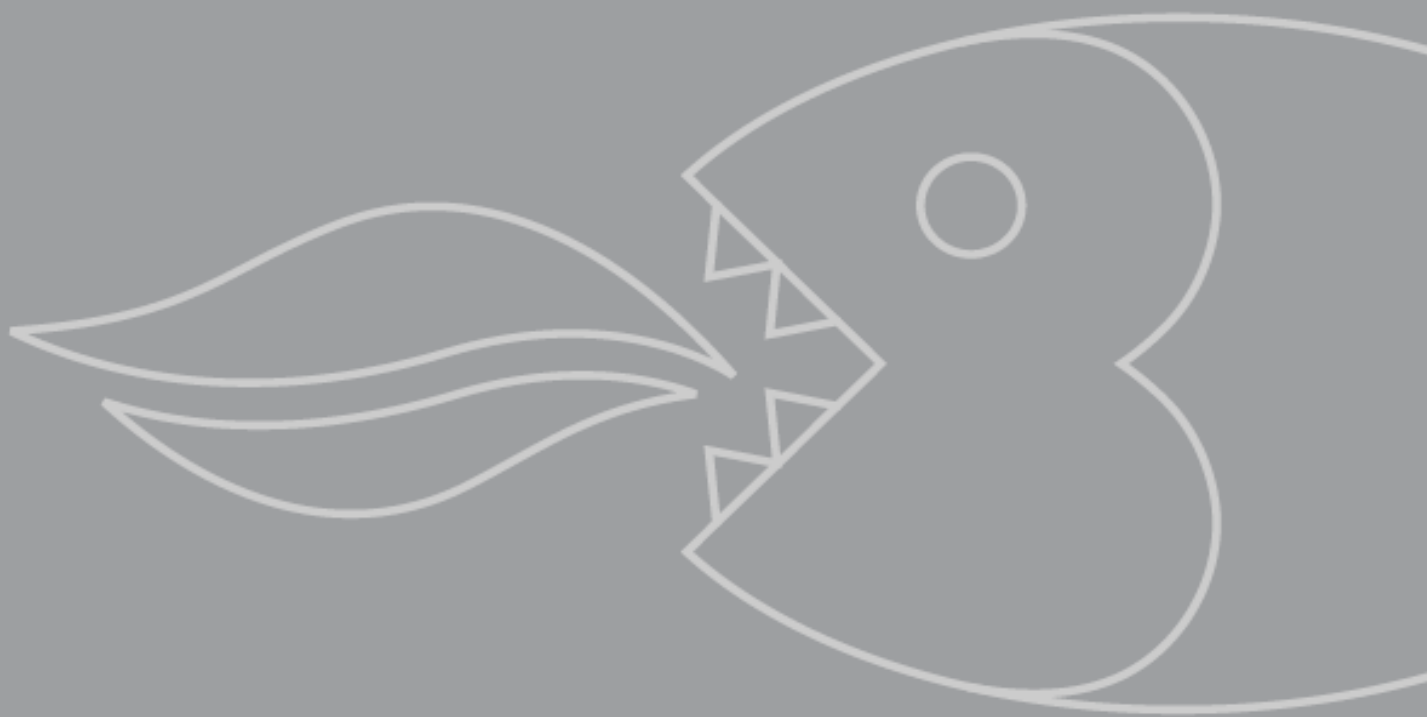

Baumatic®

User Manual for your Baumatic

WD01SS 14cm High warming drawer

WD02SS 30cm High warming drawer

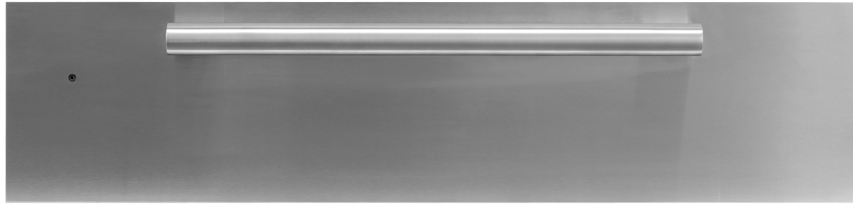

NOTE: This User Instruction Manual contains important information, including safety & installation points, which will enable you to get the most out of your appliance. Please keep it in a safe place so that it is easily available for future reference; for you or any person not familiar with the operation of the appliance.

GS 19/08/10

Contents

Environmental note	4
Important safety information	5 – 7
Specifications	8 - 11
WD01SS dimensions	8
WD02SS dimensions	9
Product specifications	10
Electrical details	10
The warming drawer	11
Using the warming drawer	11 - 14
Before first use	11 - 12
Setting the drawer to warm	12
Selecting a temperature	12 - 13
Heating times	13
Load capacity	13 - 14
Cleaning and maintenance	14 - 15
Installation	15 - 20
Electrical connections	15 - 16
Installing the warming drawer into the kitchen cabinet	16 - 20
Positioning the appliance (with an oven)	16 - 18
Positioning the appliance (without an oven)	19 - 20
My appliance isn't working correctly	21
Contact details	22

Environmental note

This appliance is marked according to the European directive 2002/96/EC on Waste electrical and Electronic Equipment (WEEE). By ensuring this product is disposed of correctly, you will help prevent potential negative consequences for the environment and human health, which could otherwise be caused by inappropriate waste handling of this product.

The symbol  on the product, or on the documents accompanying the product, indicates that this appliance may not be treated as household waste. Instead it shall be handed over to the applicable collection point for the recycling of electrical and electronic equipment.

Disposal must be carried out in accordance with local environmental regulations for waste disposal.

For more detailed information about treatment, recovery and recycling of this product, please contact your local city office, your household waste disposal service or the shop where you purchased the product.



- The packaging materials that Baumatic uses are environmentally friendly and can be recycled.
- Please discard all packaging material with due regard for the environment.

IMPORTANT SAFETY INFORMATION



Your safety is of the utmost importance to Baumatic. Please make sure that you read this instruction booklet **before** attempting to install or use the appliance. If you are unsure of any of the information contained in this booklet, please contact the Baumatic Technical Department.

General Information

- This appliance is designed for domestic household use and can be built into a standard kitchen cabinet or housing unit.
- **IMPORTANT:** *The adjacent furniture or housing and all materials used in the installation **must** be able to withstand a minimum temperature of 85°C above the ambient temperature of the room it is located in, whilst in use.*
- Certain types of vinyl or laminate kitchen furniture are particularly prone to heat damage or discolouration at temperatures below the guidelines given above.
- Any damage caused by the appliance being installed in contravention of this temperature limit, or by placing adjacent cabinet materials closer than 4mm to the appliance, **will be the liability of the owner.**
- For use in **leisure accommodation vehicles**, please refer to the appropriate information given in the installation instructions for this appliance.
- The use of this appliance for any other purpose or in any other environment without the express agreement of the manufacturer will invalidate any warranty or liability claim.
- Your new appliance is guaranteed against electrical or mechanical defects, subject to certain exclusions that are noted in Baumatic's Conditions Of Guarantee. The foregoing does not affect your statutory rights.
- **Repairs may only be carried out by Baumatic Service Engineers or their authorised service agent.**

Warning and safety instructions

- This appliance complies with all current European safety legislation. Baumatic do wish to emphasise that this compliance does not remove the fact that the appliance surfaces **will become hot during use and retain heat after operation.**

Child Safety

- We strongly recommend that babies and young children are prevented from being near to the appliance and not allowed to touch the appliance **at any time.**
- If it is necessary for younger family members to be in the kitchen, please ensure that they are kept under close supervision at all times.

General Safety

- **Do not** allow electrical fittings or cables to come into contact with areas on the appliance that get hot.
- **Do not** lean or sit on the open drawer, the telescopic runners will become damaged.
- **Do not** use the appliance to heat the room it is located in or to dry clothing.
- **Do not** install the appliance next to curtains or soft furnishings.
- **Do not** keep plastic or flammable objects inside the appliance.
- **Do not** use the appliance to warm, re-heat or cook foods or beverages.
- **Do not** insert **ANY** objects through the slots in the protective grill that covers the heating element and fan.

Cleaning

- Cleaning of the warming drawer should be carried out on a regular basis.
- Great care should be taken whilst using this appliance and when following the cleaning procedure.
- **IMPORTANT:** *The appliance must be disconnected from the mains before following the cleaning procedure.*

Installation



This appliance must be correctly installed by a suitably qualified person, strictly in accordance with the manufacturer's instructions.

- ***Baumatic Ltd declines any responsibility for injury or damage, to person or property, as a result of improper use or installation of this appliance.***
- Heat, steam and moisture will be created during use of the appliance, take care to avoid injury and ensure that the room is adequately ventilated. If the appliance is going to be used for prolonged periods of time, then additional ventilation may be required.
- Make sure that the appliance is firmly secured to the cabinet.
- Please consult with your qualified installer if you are in any doubt about the amount of ventilation that you will require.

Declaration of conformity

- In the parts destined to come into contact with foodstuffs, this appliance is in accordance with the requirements of the EC directive 89/109 transposed in the Italian Legislative Decree No. 108 of 25/01/92.
- **CE:** Appliance conforming to the European directives 89/336/EEC, 93/68/EEC, 73/23/EEC and subsequent revisions and "RoHS" directive 2002/95/CE.*
- The manufacturer declares that the warming drawer is built using certified materials and requires the appliance to be installed in accordance with the standards currently in force. This appliance must be used by a trained person for domestic purposes only.
- * The RoHS directive stands for "the restriction of the use of certain hazardous substances in electrical and electronic equipment". This directive bans the placing on the EU market of new electrical and electronic equipment containing more than the agreed levels of lead, cadmium, mercury, hexavalent chromium, polybrominated biphenyl (PBB) and polybrominated diphenyl ether (PBDE) flame retardants.

Specifications

WD01SS

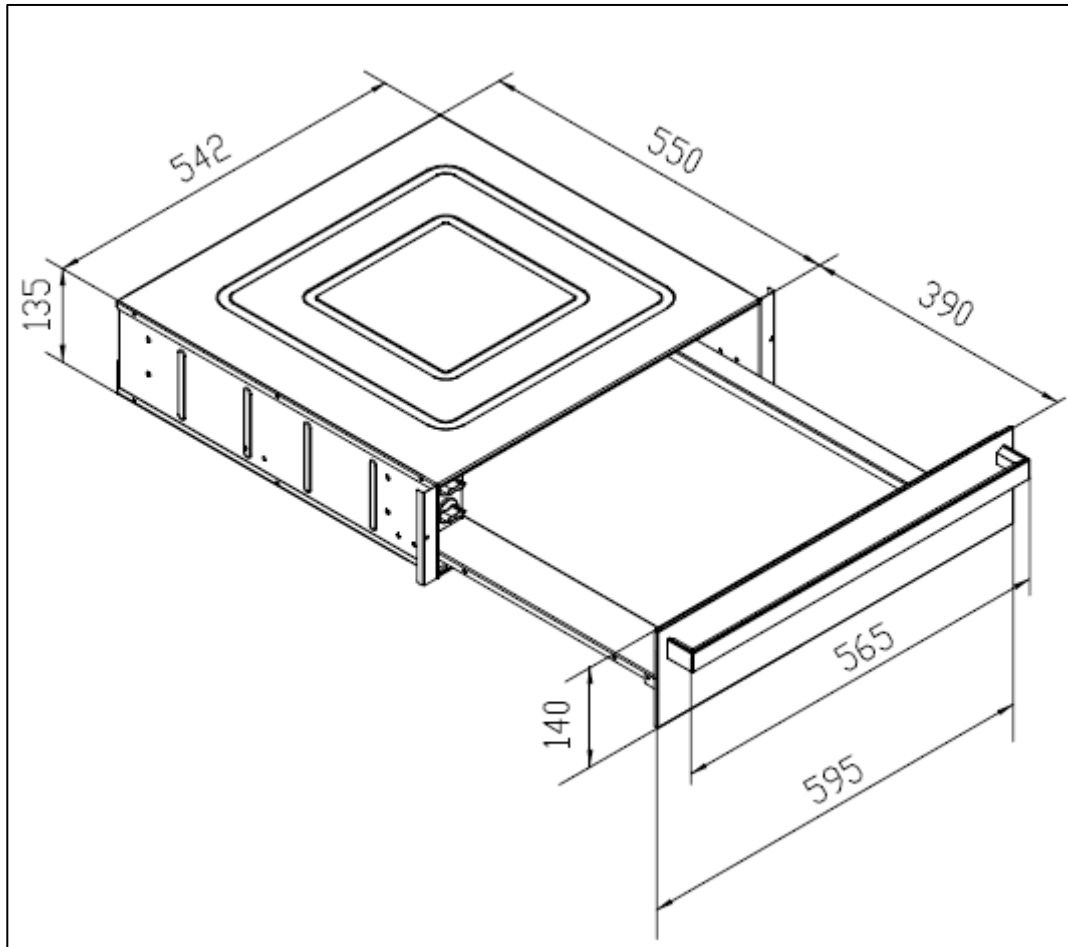

Product dimensions

Height: 140 mm
Width: 595 mm
Depth: 550 mm

Aperture dimensions*

Height: 585 mm (with oven)
Width: 560 mm
Depth: 550 mm

* For more specific information on the size of the aperture required to install the warming drawer, please see the "Installation" section of this manual.

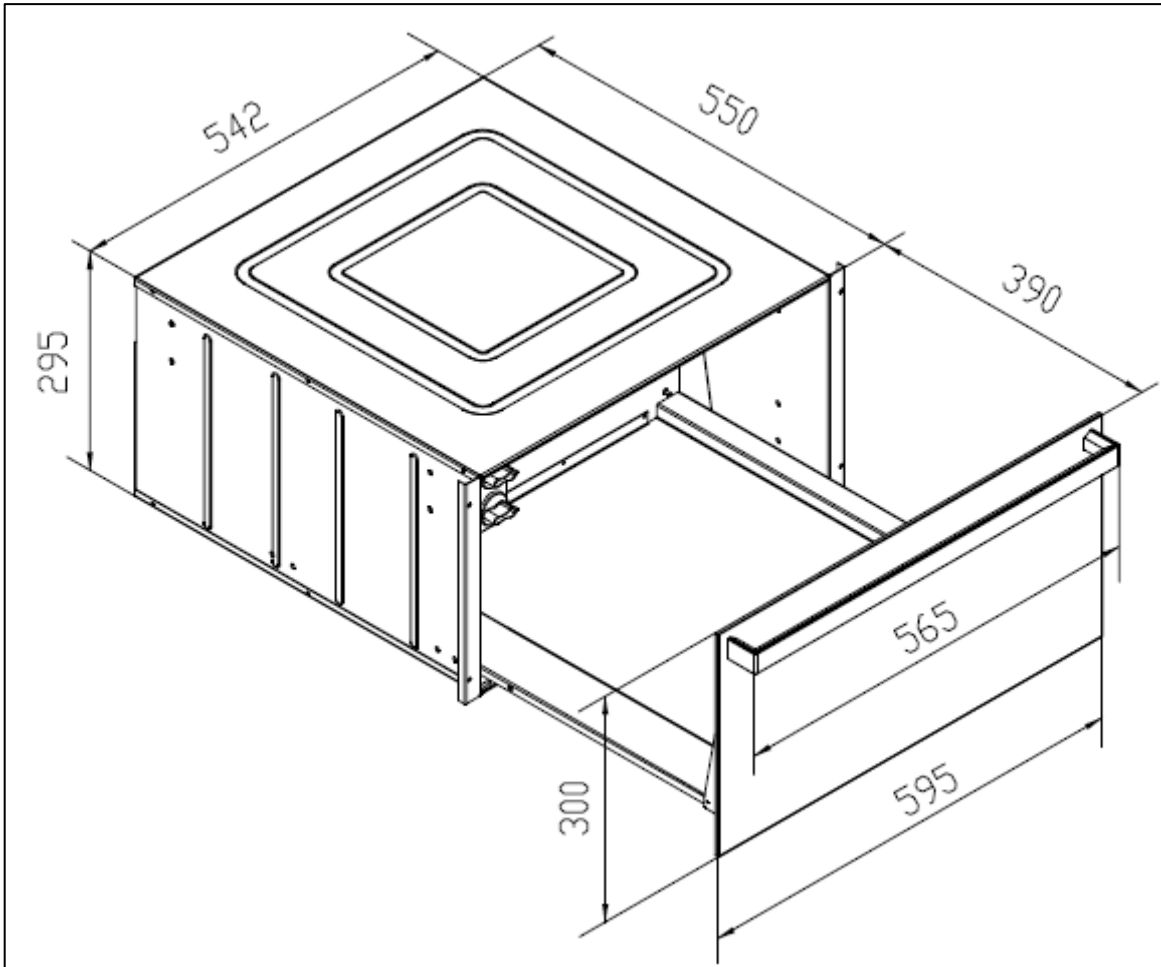

Product dimensions

Height: 300 mm
Width: 595 mm
Depth: 550 mm

Aperture dimensions*

Height: 880 mm (with oven)
Width: 560 mm
Depth: 550 mm

* For more specific information on the size of the aperture required to install the warming drawer, please see the "Installation" section of this manual.

Product specifications

WD01SS

- Adjustable temperature (30°C to 70°C)
- Integrated hot air fan
- Heater on the side
- Fully expandable telescopic drawer
- Holds 6 place settings
- Maximum load: 20 kg
- Can be installed alone or together with a single or compact oven

WD02SS

- Adjustable temperature (30°C to 70°C)
- Integrated hot air fan
- Fully expandable telescopic drawer
- Holds 12 place settings
- Maximum load: 20 kg
- Designed to be installed alone or together with single or compact oven

Electrical details (both models)

Rated Voltage:	220 - 240 Vac 50 Hz
Supply Connection:	13 A (double pole switched fused outlet with 3mm contact gap)
Max Rated Inputs:	0.41 kW
Mains Supply Lead:	3 x 1.5mm ²

For future reference please record the following information which can be found on the Rating Plate and the date of purchase which can be found on your sales invoice.

Model Number

Serial Number

Date of Purchase

The warming drawer

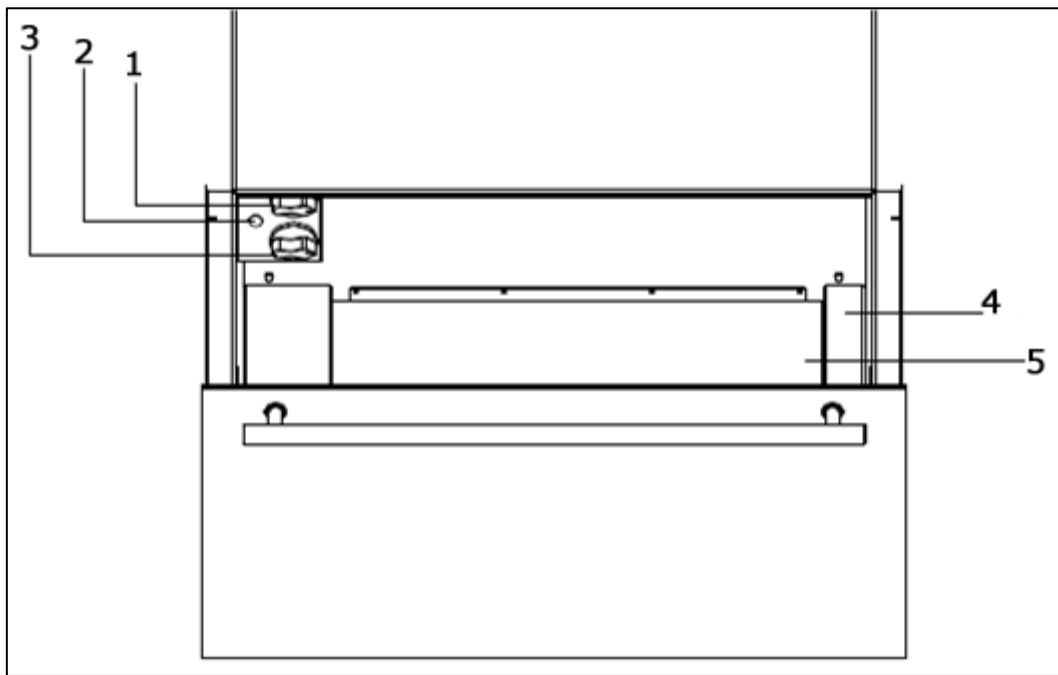

- 1) Temperature control dial
- 2) Power light
- 3) Timer switch
- 4) Drawer for dishes
- 5) Anti-skid mat

- The controls are only visible when the warming drawer is open.
- When the drawer is closed, the power light on the front of the drawer comes on to show the appliance is running.
- The floor of the drawer is covered with an anti-skid mat that prevents the dishes from sliding when the drawer is opened and closed.

Using the warming drawer

Before first use

- Clean the surfaces with a soft damp cloth.
- To remove any residue from the warming drawer that may have been left from the manufacturing process, you should turn the control knob to the maximum temperature setting.
- It is perfectly normal for a smell to be produced during this process.

- You should make sure that any windows in the room are left open during this process.
- It is advisable for you not to remain in the room whilst the burning off process is taking place.
- You should leave the warming drawer on the maximum setting for 2 hours.

Setting the drawer to warm

- Place the dishes into the drawer.
- Select the temperature (see below section).
- Set the warming time using the timer dial **(3)**. The minimum time that can be set is 10 minutes. The maximum time that can be set is 90 minutes.
- The power light **(2)** turns on to show that the appliance is switched on.
- Close the warming drawer.
- When the set time has elapsed, the hot air heating system stops and a bell will sound.
- To turn the bell off, turn the temperature dial to "0".

Selecting a temperature

- Place the crockery that you wish to warm in the drawer.
- Use the control knob **(1)** to set the most suitable temperature for the crockery that you are warming. The temperature control knob adjusts the temperature between 30°C and 70°C.
- The temperature should be set at 40°C to warm cups or glasses. This may be ideal for gently heating cups before pouring a hot drink in them so that it stays hotter longer.
- The temperature should be set at 60°C to warm plates and dishes. Food served on preheated plates or dishes maintain their heat but the dishes can still be touched without risking burns.
- ***IMPORTANT: Care should be taken when removing items from the warming drawer, when appropriate you should use oven gloves when removing items from the drawer.***

You should make sure that the appliance is switched off before removing items from the drawer.

Heating times

The time required to heat crockery, depends on several factors:-

- The material that the crockery is manufactured from and the thickness of the crockery.
- The amount that has been loaded into the warming drawer.
- The way in which the load has been arranged.
- The temperature setting that has been selected.

It is not possible to give an exact heating time and you should experiment to find out which heating temperature and time are the most appropriate for particular types and amounts of crockery. As a general guide for a temperature setting of 60°C to heat evenly:

- Dishes for a meal with six people take approximately 30 minutes.
- Dishes for a meal with twelve people take approximately 40 minutes.

Load capacity

IMPORTANT: The drawer can withstand a maximum load of 20 kilograms.

WD01SS

<i>Load capacities</i>	<i>Dimensions (Ø)</i>
6 x dinner plates	28 cm
6 x soup bowls	22 cm
1 x serving dish	22 cm
1 x serving dish	20 cm
1 x serving dish	18 cm
2 x meat plates	36 cm
16 x large plates	28 cm
8 x bowls	10 cm
24 x soup bowls	22 cm
40 x bowls	10 cm
60 x cups	8 cm

Load capacities	Dimensions (Ø)
12 x dinner plates	28 cm
12 x soup bowls	22 cm
2 x serving dishes	22 cm
2 x serving dishes	20 cm
2 x serving dishes	18 cm
2 x meat plates	36 cm
32 x large plates (600g each)	28 cm
50 x large plates (400g each)	22 cm
60 x bowls	10 cm
132 x cups	8 cm

Cleaning and maintenance



Cleaning operations must only be carried out when the drawer is cool.

The appliance should be disconnected from your mains supply before commencing any cleaning process.

- **Never** clean the drawer surfaces by steam cleaning.
- All surfaces of the warming drawer should only be cleaned with warm soapy water, using either a sponge or soft cloth. No abrasive cleaners should be used.
- **IMPORTANT:** *The slots in the protective grill that covers the heating element and fan should not be cleaned with water. Any water penetration into this area may result in the breakdown of the appliance, short circuits and/or create a hazard for the user.*
- If you use any form of cleaner on your appliance, then you must check with the manufacturer of the cleaner that it is suitable for use on your appliance.
- To maintain the appearance of the stainless steel drawer front, a good quality stainless steel cleaner should be utilised. Please refer to the manufacturer's instructions when using a stainless steel cleaner.
- **DO NOT USE** detergents that contain soda, acids or chlorine, abrasive detergents (powders or cream), abrasive sponges (e.g.

steel wool pads) or sponges that contain a residual abrasive detergent.

- The anti-slip warming drawer bottom can be cleaned if you are thoroughly cleaning the appliance. It can be hand-washed with warm water and a mild detergent. The bottom should be dried thoroughly afterwards and not placed back into the appliance until it is completely dry.
- ***Any damage that is caused to the appliance by a cleaning product will not be fixed by Baumatic free of charge, even if the appliance is within the guarantee period.***

INSTALLATION



The installation must be carried out by a suitably qualified person, in accordance with the current version of the following.

- UK Regulations and Safety Standards or their European Norm Replacements.
- ***Building Regulations*** (issued by the Department of the Environment).
- ***Building Standards*** (issued by the Scottish Development Department).
- ***IEE Wiring Regulations.***
- ***Electricity At Work Regulations.***

Before connecting the appliance, make sure that the supply voltage marked on the Rating Plate corresponds with your mains supply voltage.

WARNING: THIS APPLIANCE MUST BE EARTHED.

- This appliance should be wired into a 13 A double pole switched fused spur outlet, having 3 mm contact separation and placed in an easily accessible position adjacent to the appliance. The spur outlet must still be accessible even when your warming drawer is located in its housing.

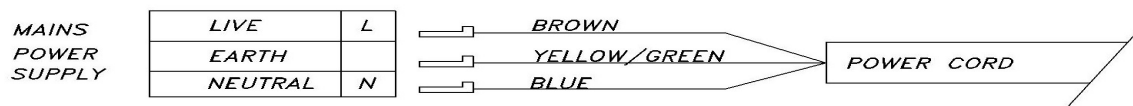

- To connect the power cord, loosen and remove the cover on the terminal block, in order to gain access to the contacts inside. Make the connection, securing the cord in place with the cable clamp provided and then immediately close the terminal block cover again.

- If you have to change the power cord, the earthing (yellow/green) conductor must always be 10 mm longer than the line conductors.
- Care must be taken to ensure that the temperature of the mains supply cable does not exceed 50°C.
- If the mains supply cable is damaged, then it must be replaced by an appropriate replacement which can be obtained from the Spares Department.

Installing the warming drawer into the kitchen cabinet

Positioning the appliance (with an oven)

- Ensure that the aperture that you will be fitting the warming drawer into is of the size given in the diagrams below.
- The warming drawer must be fitted into a housing unit with the correct ventilation requirements provided, according to the instructions of the oven manufacturer.
- Ensure that the rear panel of the furniture housing unit has been removed.

WD01SS

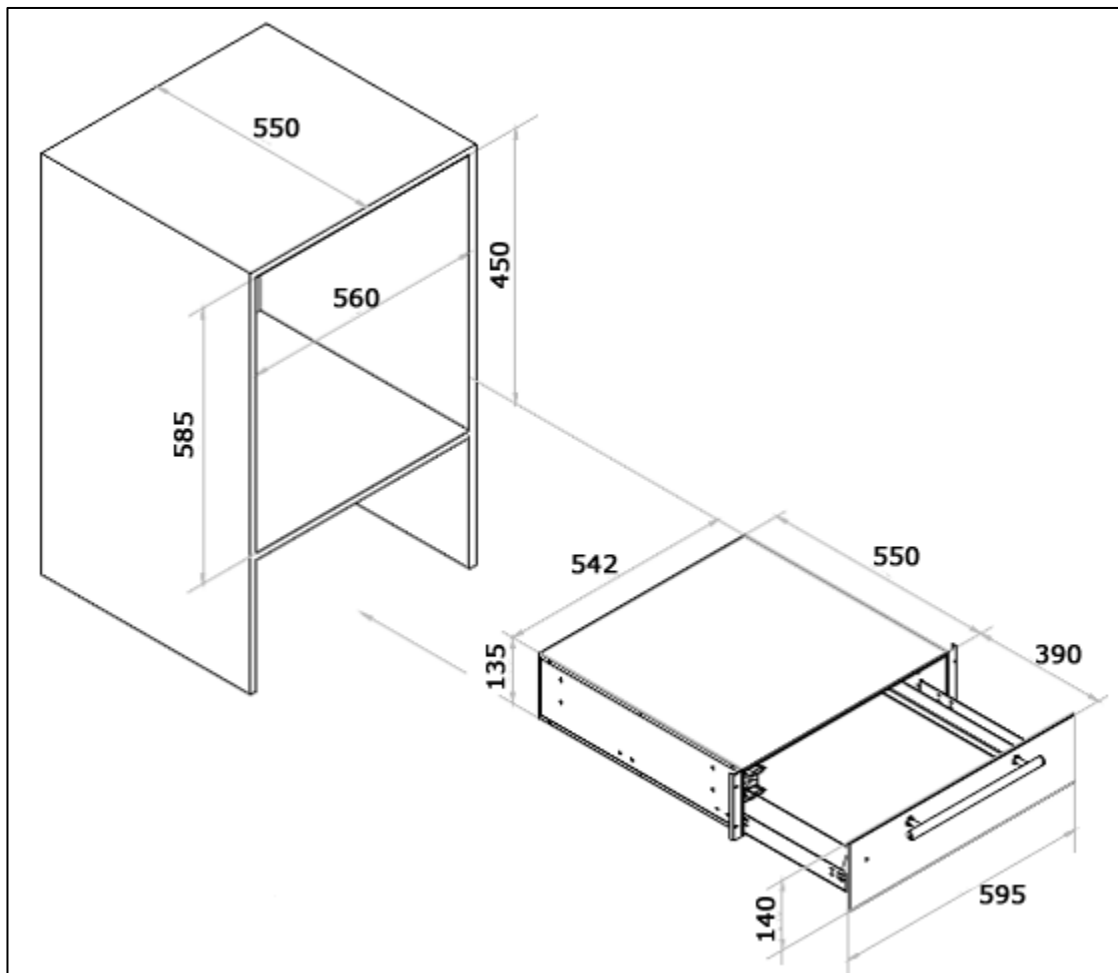

- Carefully place the appliance into the aperture, ensuring that it is positioned in the centre.
- Open the drawer and fasten the appliance to the sides of the cabinet with the two screws and two spacers provided.

WD02SS

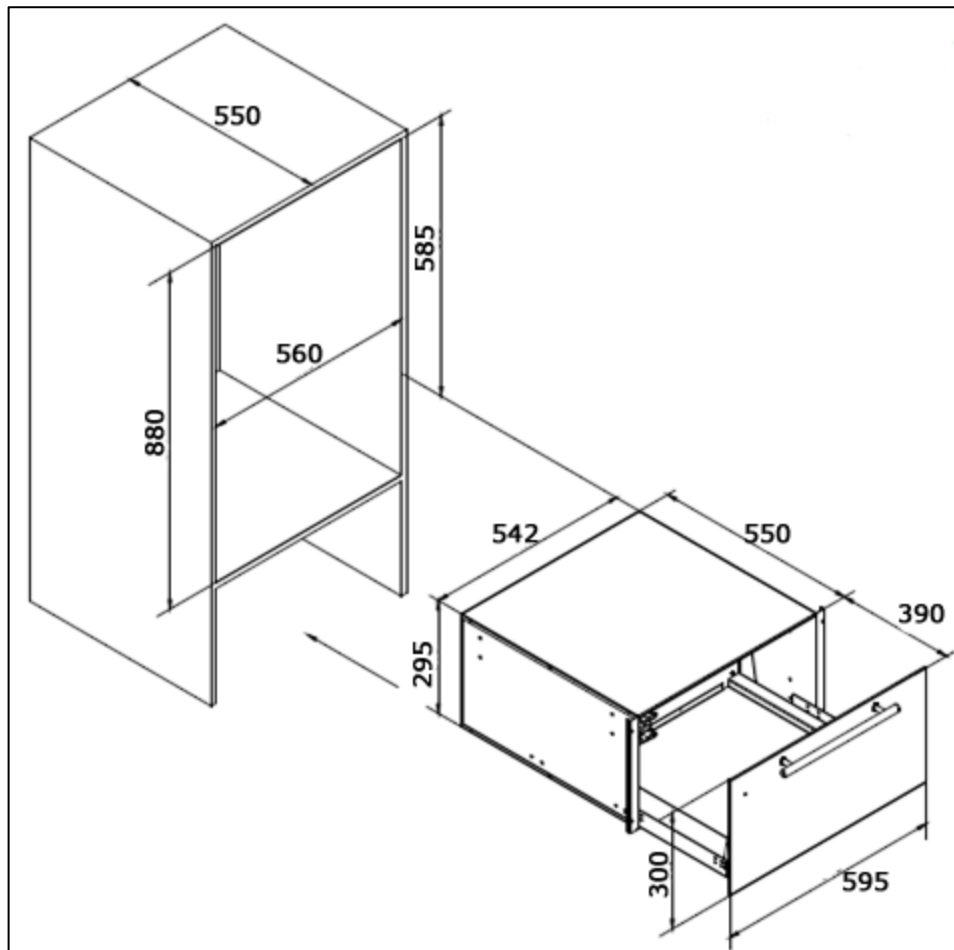

- Carefully place the appliance into the aperture, ensuring that it is positioned in the centre.
- Open the drawer and fasten the appliance to the sides of the cabinet with the two screws and two spacers provided.

Positioning the appliance (without an oven)

- Ensure that the aperture that you will be fitting the warming drawer into is of the size given in the diagrams below.
- Ensure that the rear panel of the furniture housing unit has been removed.

WD01SS

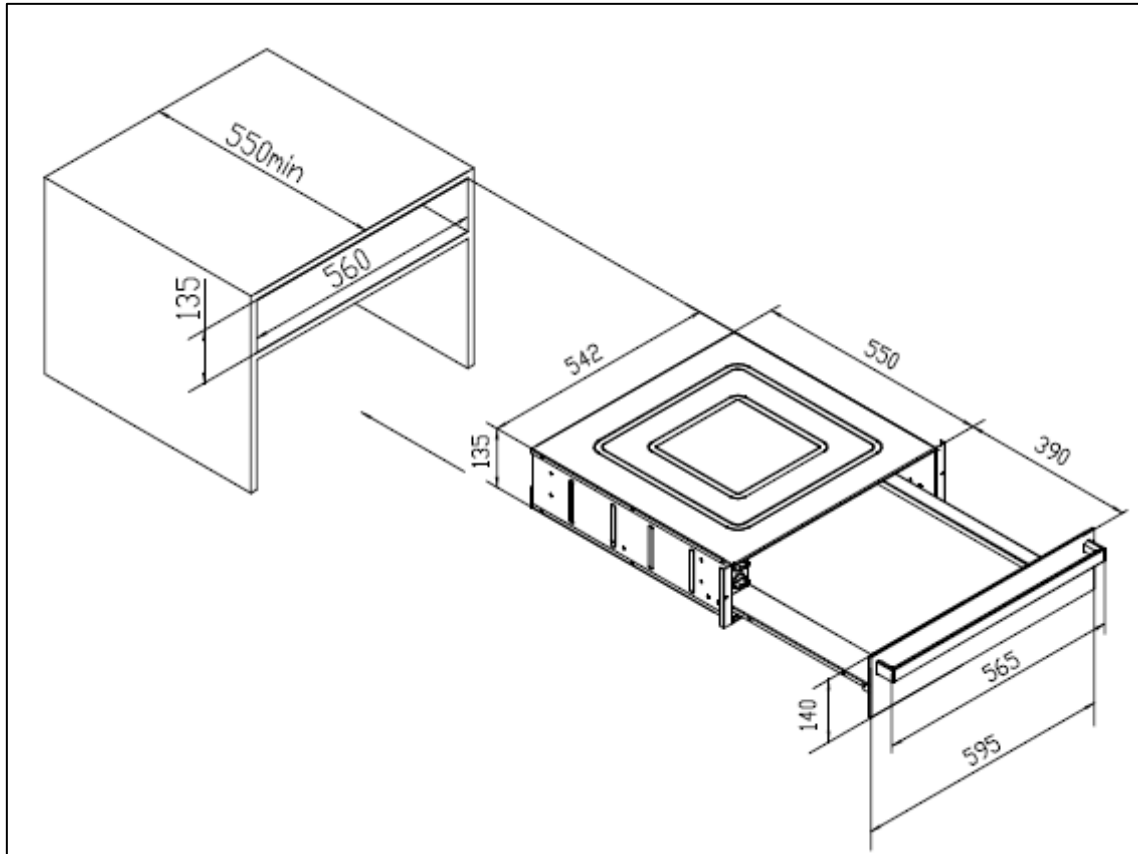

- Carefully place the appliance into the aperture, ensuring that it is positioned in the centre.
- Open the drawer and fasten the appliance to the sides of the cabinet with the two screws and two spacers provided.

WD02SS

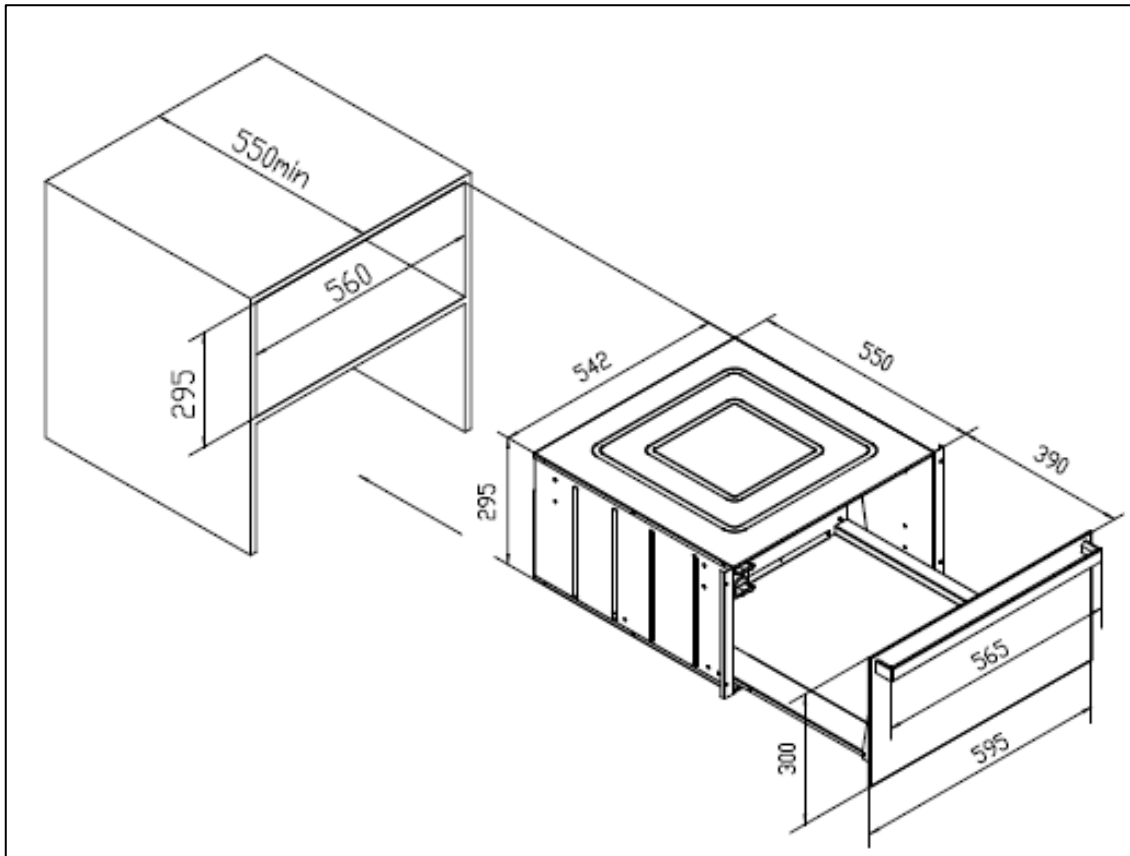

- Carefully place the appliance into the aperture, ensuring that it is positioned in the centre.
- Open the drawer and fasten the appliance to the sides of the cabinet with the two screws and two spacers provided.

My appliance isn't working correctly

- **The warming drawer isn't heating crockery.**
 - * Check that the appliance is switched on.
 - * Check that the drawer is closed completely.
 - * Check that the crockery has been warmed for a sufficient period of time.
 - * Check that the drawer has not been left open for too long.
 - * Check your mains power supply.
- **The drawer does not close properly.**
 - * Check that the loading of the drawer allows it to shut properly.



IMPORTANT: If your appliance appears not to be operating correctly, then you should disconnect it from your mains supply and then contact the Baumatic Service Department on telephone number (0118) 933 6911.

DO NOT ATTEMPT TO REPAIR THE APPLIANCE YOURSELF.

Please note that if an engineer is asked to attend whilst the product is under guarantee and finds that the problem is not the result of an appliance fault, then you may be liable for the cost of the call out charge.

The appliance must be accessible for the engineer to perform any necessary repair. If your appliance is installed in such a way that an engineer is concerned that damage will be caused to the appliance or your kitchen, then he will not complete a repair.

This includes situations where appliances have been tiled in, sealed in with sealant, have wooden obstructions placed in front of the appliance, like plinths. Or any installation other than the one specified by Baumatic Ltd has been completed.



United Kingdom

Baumatic Ltd.,
Baumatic Buildings,
6 Bennet Road,
Reading, Berkshire
RG2 0QX
United Kingdom

Sales Telephone

(0118) 933 6900

Sales Fax

(0118) 931 0035

Customer Care Telephone

(0118) 933 6911

Customer Care Fax

(0118) 986 9124

Spares Telephone

(01235) 437244

Advice Line Telephone

(0118) 933 6933

E-mail:

sales@baumatic.co.uk
customercare@baumatic.co.uk
spares@baumatic.co.uk
technical@baumatic.co.uk

Website:

www.baumatic.co.uk

Republic of Ireland

Service Telephone

1-890 812 724

Spares Telephone

091 756 771

Czech Republic

Baumatic CR spol s.r.o.
Průmyslová zóna Sever 696
460 11 Liberec 11
Czech Republic

+420 483 577 200

www.baumatic.cz

Slovakia

Baumatic Slovakia, s.r.o.
Galvániho 7/D
Slovakia

+421 255 640 618

Germany

Baumatic GmbH
Lilienthalstrasse 1
320 52 Herford
Deutschland

+49 5221 694 99-0

www.baumatic.de

Italy

Baumatic Italia S.R.L.
Via Galvani N.3
35011 Campodarsego (PD)

+3904 9920 2297

www.baumatic.it

Holland

Baumatic Benelux B.V.
Grindzuigerstraat 22
1333 MS ALMERE
Nederland

+3136 549 1555

www.baumatic.nl

