

B0796.5SS/BL

**72 cm Built-under
electric double
oven**

INSTRUCTION MANUAL

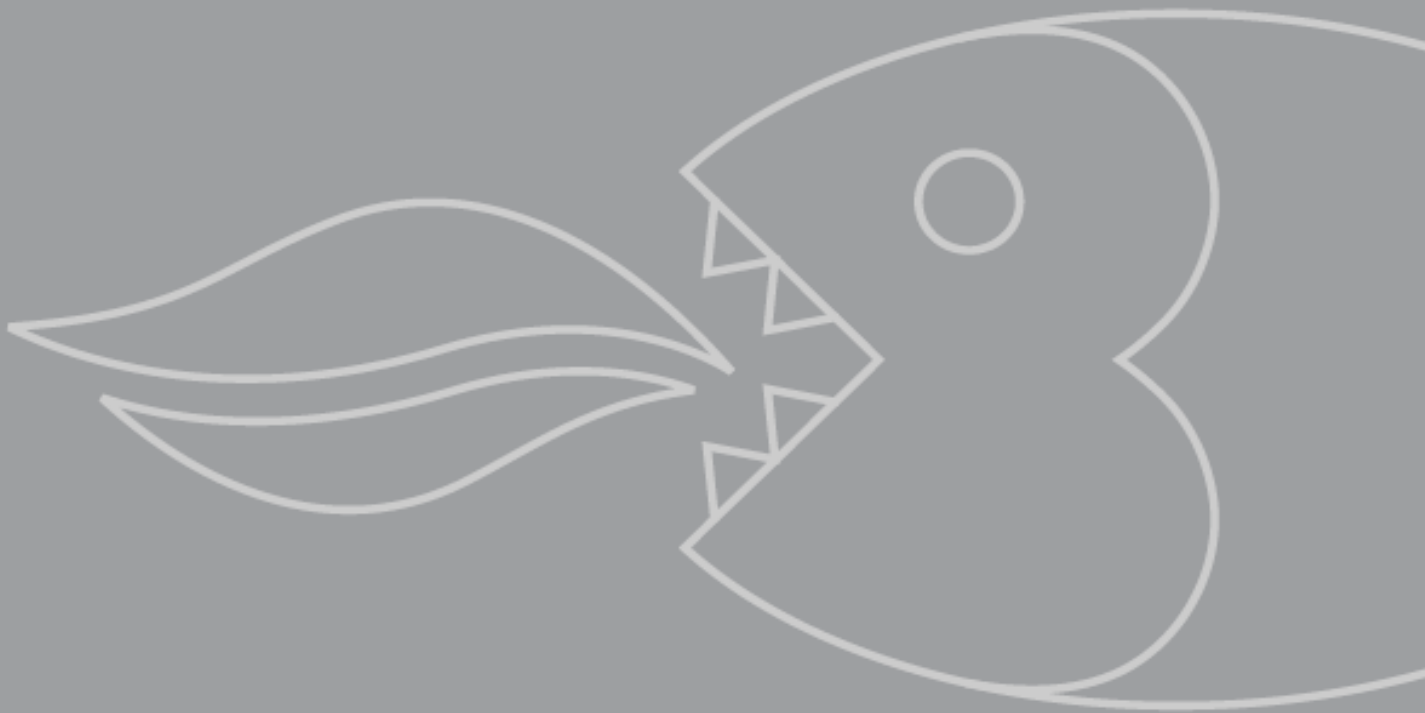

User Manual for your Baumatic

B0796.5SS/BL

**72 cm Built-under electric
double oven**



NOTE: This User Instruction Manual contains important information, including safety & installation points, which will enable you to get the most out of your appliance. Please keep it in a safe place so that it is easily available for future reference; for you or any person not familiar with the operation of the appliance.

JW 11/07/12

Contents

Environmental note	4
Important safety information	5 – 8
Specifications	9 - 10
Product and aperture dimensions	9
Product specifications	9
Standard accessories	10
Optional extra	10
Electrical details	10
Cooling fan	10
Initial set up of your oven	11-13
Before first use	11
Control panel	12
Oven programmer/Timer display	12
Timer functions	13-18
The minute minder function	13
The semi-automatic cooking function	14
The end of cooking function	15
The automatic cooking function	16
Cancelling the semi-automatic and automatic function	17
Cancelling the minute minder function	17
Adjusting the volume of the audible signal	17
Changing the time of day	18
Selecting a cooking function and temperature	18-21
Selecting a top oven function and temperature	18
Top oven functions	18
Selecting a bottom oven function and temperature	19
Bottom (main) oven functions	19
Oven operating lights (main and secondary oven)	20
Using the grill	20
Cooking guidelines	21
Warnings	21
Cleaning and maintenance	22-26
General cleaning	22
Removing the side racks	23
Replacing the oven bulbs (both ovens)	24
Removing the oven door for cleaning (top oven only)	25
Installation	26-30
Electrical connection	26
Connecting the mains supply cable	27
Replacing the mains supply cable	28
Built under installation	29
Positioning the appliance	29
Ventilation requirements	30
My appliance isn't working correctly	30-32
Baumatic consumables	33
Contact details	34

This appliance is marked according to the European directive 2002/96/EC on Waste electrical and Electronic Equipment (WEEE). By ensuring this product is disposed of correctly, you will help prevent potential negative consequences for the environment and human health, which could otherwise be caused by inappropriate waste handling of this product.

The symbol  on the product, or on the documents accompanying the product, indicates that this appliance may not be treated as household waste. Instead it shall be handed over to the applicable collection point for the recycling of electrical and electronic equipment.

Disposal must be carried out in accordance with local environmental regulations for waste disposal.

For more detailed information about treatment, recovery and recycling of this product, please contact your local city office, your household waste disposal service or the shop where you purchased the product.

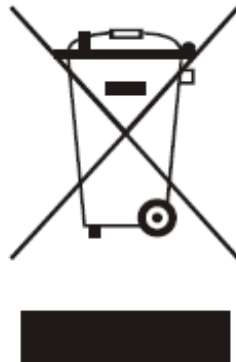

- The packaging materials that Baumatic uses are environmentally friendly and can be recycled.
- Please discard all packaging material with due regard for the environment.

IMPORTANT SAFETY INFORMATION



Your safety is of the utmost importance to Baumatic. Please make sure that you read this instruction booklet **before** attempting to install or use the appliance. If you are unsure of any of the information contained in this booklet, please contact the Baumatic Advice Line.

General Information

- This appliance is designed for domestic household use and can be built under a standard worktop.
- **IMPORTANT:** *The adjacent furniture or housing and all materials used in the installation **must** be able to withstand a minimum temperature of 85°C above the ambient temperature of the room it is located in, whilst in use.*
- Certain types of vinyl or laminate kitchen furniture are particularly prone to heat damage or discolouration at temperatures below the guidelines given above.
- Any damage caused by the appliance being installed in contravention of this temperature limit, or by placing adjacent cabinet materials closer than 4mm to the appliance, **will be the liability of the owner.**
- For use in **leisure accommodation vehicles**, please refer to the appropriate information given in the installation instructions for this appliance.
- **IMPORTANT:** *Baumatic Ltd. **DO NOT** recommend that this appliance is installed on any type of marine vessel.*
- The use of this appliance for any other purpose or in any other environment without the express agreement of Baumatic Ltd. will invalidate any warranty or liability claim.
- Your new appliance is guaranteed against electrical or mechanical defects, subject to certain exclusions that are noted in Baumatic's Conditions Of Guarantee. The foregoing does not affect your statutory rights.
- **Repairs may only be carried out by Baumatic service engineers or their authorised service agent.**

Warning and safety instructions

- This appliance complies with all current European safety legislation. Baumatic do wish to emphasise that this compliance does not remove the fact that the appliance surfaces ***will become hot during use and retain heat after operation.***

Child Safety

- Baumatic strongly recommend that babies and young children are prevented from being near to the appliance and not allowed to touch the appliance ***at any time.*** During and after use, all surfaces will become hot.
- If it is necessary for younger family members to be in the kitchen, please ensure that they are kept under close supervision at all times.

General Safety

- Make sure that you understand the controls before using the appliance.
- Check that all of the controls on the appliance are switched off after use.
- Always stand back when opening the oven door, this will allow heat to disperse.
- Take care when removing items from the oven, as the contents may be hot.
- Always keep the oven door closed when the oven is not in use.
- Always follow the basic principles of food handling and hygiene; this will prevent the possibility of bacterial growth.
- Always keep ventilation slots clear of obstructions.
- Keep fingers away from the hinge areas when closing the door, otherwise you may trap them.
- Oven gloves should be used when placing food in the oven cavity and when removing it. Care should be taken to avoid direct contact with either of the burners in the appliance.
- ***DO NOT LEAVE THE APPLIANCE UNATTENDED WHILST IN USE.***

- **Do not** place heavy objects on the oven door or lean on the oven door when it is open, as this can cause damage to the oven door hinges. Nobody should be allowed to sit or stand on any part of the oven.
- **Do not** heat up unopened food containers, as pressure can build up which may cause the container to burst.
- **Do not** place flammable or plastic items in the oven.
- **Do not** leave heated oil or fat unattended, as this is a fire risk.
- **Do not** allow fat or oil to build up in the oven trays, enamelled baking tray or oven base.
- **Do not** place pans or baking trays directly on the base of the oven cavity, or line it with aluminium foil.
- **Do not** grill food containing fat without using the grill trivet. The grill trivet should never be covered with aluminium foil.
- **Do not** place hot enamel parts in water, leave them to cool first.
- **Do not** allow vinegar, coffee, milk, saltwater, lemon, tomato juice or any liquid with high sugar content to remain in contact with the enamel parts of the appliance. Spillages should be wiped up immediately.
- **Do not** allow electrical fittings or cables to come into contact with areas on the appliance that get hot.
- **Do not** use the appliance to heat the room it is located in or to dry clothing. No clothing should be placed over or near to the oven door.
- **Do not** install the appliance next to curtains or soft furnishings.
- **Do not** attempt to lift or move cooking appliances by using the oven door or handle, as this may cause damage to the appliance or result in injury to the person lifting the appliance.
- **Do not** store chemicals, food stuffs, pressurised containers in or on the oven or in cabinets immediately above or next to the oven.

Cleaning

- Cleaning of the oven should be carried out on a regular basis.
- Great care should be taken whilst using this appliance and when following the cleaning procedure.
- **IMPORTANT:** *The appliance must be disconnected from the mains before following the cleaning procedure.*

Installation



This appliance must be correctly installed by a suitably qualified person, strictly in accordance with the manufacturer's instructions. Please see the specific section of this booklet that refers to installation.

- ***Baumatic Ltd. declines any responsibility for injury or damage, to person or property, as a result of improper use or installation of this appliance.***
- Heat, steam and moisture will be created during use of the appliance, take care to avoid injury and ensure that the room is adequately ventilated. If the appliance is going to be used for prolonged periods of time, then additional ventilation may be required.
- Please consult with your qualified installer if you are in any doubt about the amount of ventilation that you will require.

Declaration of conformity

This appliance complies with the following European Directives:

- 2006/95/EC regarding "low voltage"
- 2004/108/EC regarding "electromagnetic disturbances"
- Regulation (EC) N° 1935/2004 regarding "materials in contact with food"
- The above directives comply with 93/68/EEC regarding CE marking.
- The manufacturer declares that the oven is built using certified materials and requires the appliance to be installed in accordance with the standards currently in force. This appliance must be used by a trained person for domestic purposes only.

Specifications

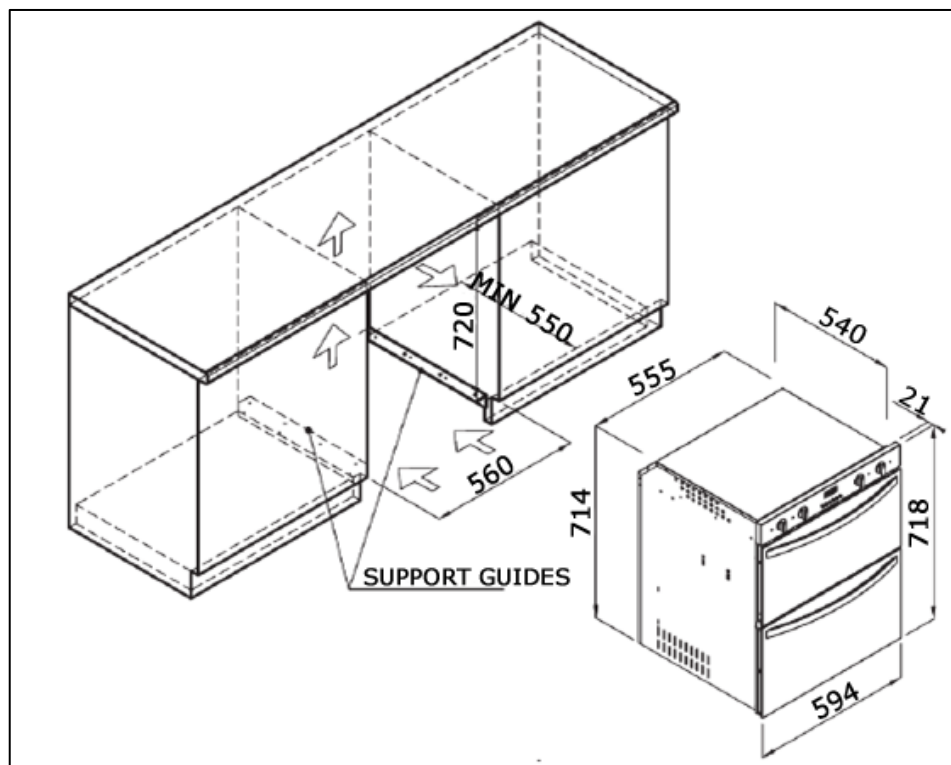

Product Dimensions

Height: 718 mm
Width: 594 mm
Depth: 540 mm

Aperture dimensions

Height: 720 mm
Width: 560 mm
Depth: 550 mm MIN

Product specifications

- Energy efficiency class: B/A
- LED full programmer
- Cooling fan
- Double glazed removable doors
- **Top oven: conventional oven**
- 4 functions
- Net oven capacity: 33.4 litres
- **Main oven: fan oven**
- 4 functions
- Net oven capacity: 42 litres

Standard accessories

- 2 x Safety shelves
- 2 x Trivets
- 2 x Wipe-clean enamelled baking trays with handles
- Removable side racks

Optional extra

- BPS2 Pizza stone

Electrical details

Rated Voltage:	230 - 240 Vac 50 Hz
Supply Connection:	30A (double pole switched fused outlet with 3mm contact gap)
Max Rated Inputs:	3.75 kW
Mains Supply Lead:	3 x 2.5mm ²
Oven Light Bulb:	25 W/300°C screw type pygmy

Cooling fan

- A cooling fan is fitted inside of this appliance, to make the internal temperature of the oven stable and the external surface temperature lower.
- After you have finished cooking and switched off the oven, the cooling fan will continue to run for a period of time afterwards. The length of time will depend on how long the oven has been switched on for and at how high a temperature.

For future reference please record the following information which can be found on the rating plate and the date of purchase which can be found on your sales invoice. The rating plate for your oven can be located by opening the main oven door and looking on the frame of the oven chassis.

Model Number

Serial Number

Date of Purchase

Using your oven

Before first use

- To remove any residue from the oven cavities that may have been left from the manufacturing process, you should select the conventional or fan oven function and set the thermostat to its maximum temperature setting.
- It is perfectly normal for a smell to be produced during this process.
- You should make sure that any windows in the room are left open during this process.
- It is advisable for you not to remain in the room whilst the burning off process is taking place.
- You should leave the oven on maximum setting for 30 – 40 minutes.
- ***IMPORTANT: You should not burn off both ovens simultaneously.***
- After the oven cavities have cooled, they should then be cleaned with warm soapy water, using either a sponge or soft cloth. No abrasive cleaners should be used.
- Outer parts of the oven should be cleaned with warm soapy water, using either a sponge or soft cloth. No abrasive cleaners should be used.
- We would recommend that an appropriate stainless steel cleaner and polish is regularly used on the stainless steel surfaces of this appliance (BO796.5SS only).

Control Panel

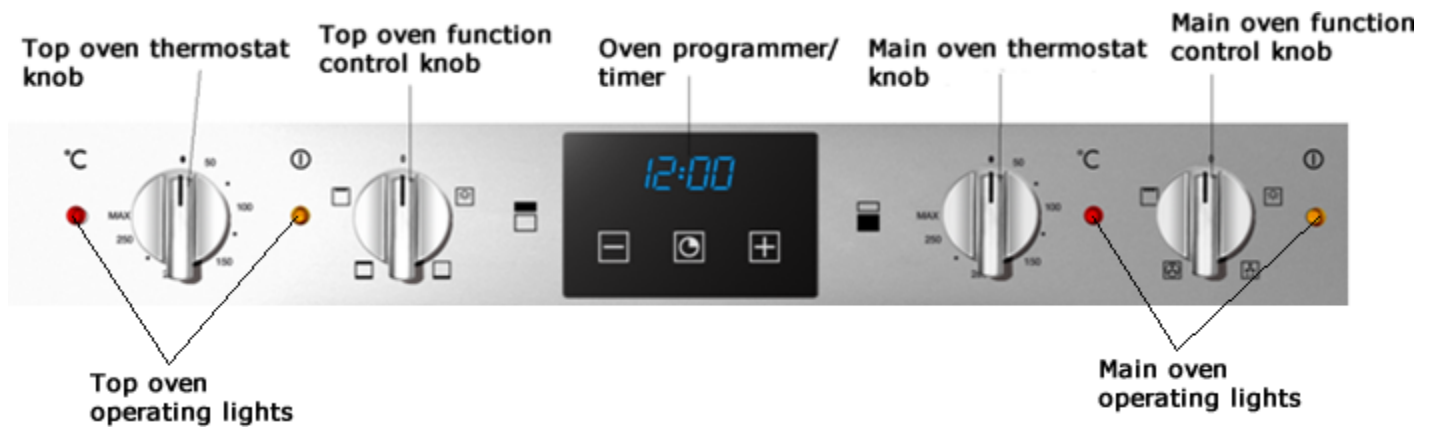

Oven programmer/timer

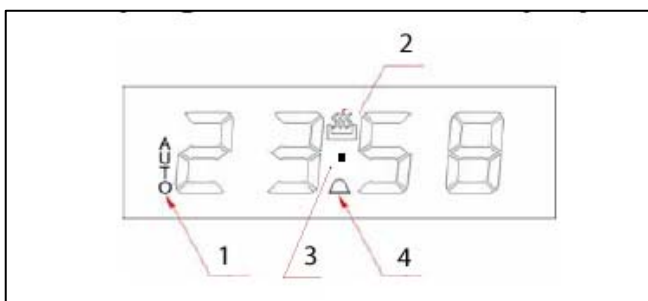

- 1) Auto cooking symbol
- 2) Oven in use symbol
- 3) Decimal point symbol
- 4) Minute minder symbol



- 5) Minus button
- 6) Programme button
- 7) Plus button

Initial set-up of your oven

Setting the time of day

After your appliance is connected to your mains supply for the first time, you must set the time of day before you can use the oven.

- When the oven is connected to your mains supply for the first time (or after a power cut), the digits on the LED display and the automatic cooking symbol **(1)** will flash.

- Press and hold down the programme button **(6)** for a couple of seconds. The automatic cooking symbol will go out and the digits will remain steady.
- When the oven in use symbol **(2)** appears, use the plus **(7)** and minus **(5)** buttons to set the correct time of day.
- When the correct time of day is shown on the LED display, release the plus and minus buttons and wait a few seconds. A beep will sound indicating that the time is set and the oven is ready to use.

Timer functions

The minute minder function (both ovens)

The minute minder function is a countdown time that can be set on the oven programmer/timer. When the countdown time has finished, an audible signal will sound.

- Press and hold down the programme button **(6)** until the decimal point starts to flash to enter programming mode.
- Use the plus **(7)** and minus **(5)** buttons to set the countdown time that you require.
- The maximum countdown time that can be set is 23 hours and 59 minutes.
- When the correct countdown time appears on the LED display, release the plus and minus buttons and the countdown will start immediately.
- The minute minder symbol **(4)** will appear on the LED display to show that a countdown time is in progress.
- After a few seconds the LED display will return to showing the time of day.
- At the end of the countdown time, an audible signal will sound and the minute minder symbol will go out. You can silence it by pressing any of the oven programmer/timer buttons.
- **IMPORTANT:** *If the oven is in use whilst using the minute minder function, the oven WILL NOT switch off at the end of the countdown time. YOU MUST turn the oven function selector knob and the thermostat control knob to their OFF positions.*

The semi-automatic cooking function (main oven only)

This function will allow you to set a countdown time similar to the minute minder function, however the oven will switch off at the end of the cooking time.

- Place the food that you want to cook inside of the oven and close the door.
- Select an oven function and cooking temperature using the relevant control knobs.
- Press and hold down the programme button **(6)** until the decimal point starts to flash to enter programming mode, the oven in use symbol **(2)** will appear on the LED display.
- Release the programme button and then press it again. The automatic cooking symbol **(1)** will flash and "dur" will appear briefly on the LED display before showing "0.00".
- Use the plus **(7)** and minus **(5)** buttons to set the cooking time that you require.
- The maximum countdown time that can be set is 10 hours.
- When the correct countdown time appears on the LED display, release the plus and minus buttons. Cooking will begin immediately, after a few seconds the countdown time will start.
- The automatic cooking symbol **(1)** and the oven in use symbol **(2)** will appear on the LED display.
- At the end of the cooking time, an audible signal will sound and the automatic cooking symbol will flash on the LED display.
- To reset the oven and cancel the audible alarm, press the programme button until the oven in use symbol appears on the LED display and the automatic cooking symbol goes out.
- ***IMPORTANT:*** *If you have not turned the oven function selector knob and thermostat control knob to their OFF positions, when you reset the oven it will continue to heat.*

The end of cooking function (main oven only)

This function is similar to the semi-automatic function, however instead of setting a countdown time, you select the time of day that you want the oven to switch off at.

- Place the food that you want to cook inside of the oven and close the door.
- Select an oven function and cooking temperature using the relevant control knobs.
- Press and hold down the programme button **(6)** until the decimal point starts to flash to enter programming mode, the oven in use symbol **(2)** will appear on the LED display.
- Release the programme button and then press it again. The automatic cooking symbol **(1)** will flash and "dur" will appear on the LED display.
- Release the programme button and then press it for a third time, "end" will appear briefly on the LED display before showing "0.00".
- Use the plus **(7)** and minus **(5)** buttons to set the time of day that you want the oven to switch off at.
- The maximum countdown time that can be set is 10 hours.
- When the correct time of day appears on the LED display, release the plus and minus buttons. Cooking will begin immediately, after a few seconds the countdown time will start.
- The automatic cooking symbol **(1)** and the oven in use symbol **(2)** will appear on the LED display.
- At the end of the cooking time, an audible signal will sound and the automatic cooking symbol will flash on the LED display.
- To reset the oven and cancel the audible alarm, press the programme button until the oven in use symbol appears on the LED display and the automatic cooking symbol goes out.
- ***IMPORTANT:*** *If you have not turned the oven function selector knob and thermostat control knob to their OFF positions, when you reset the oven it will continue to heat.*

The automatic cooking function (main oven only)

This function will allow you to set the time of day that you want the oven to switch off at and how long you want the oven to cook for.

- Place the food that you want to cook inside of the oven and close the door.
- Select an oven function and cooking temperature using the relevant control knobs.
- Press and hold down the programme button **(6)** until the decimal point starts to flash to enter programming mode, the oven in use symbol **(2)** will appear on the LED display.
- Release the programme button and then press it again. The automatic cooking symbol **(1)** will flash and "dur" will appear briefly on the LED display before showing "0.00".
- Use the plus **(7)** and minus **(5)** buttons to set the cooking time that you require.
- The maximum cooking time that can be set is 10 hours.
- When the correct cooking time appears on the LED display, release the plus and minus buttons and wait a few second for the time to be set.
- Press the programme button again for a few seconds. Then press the programme button again twice and "end" will appear briefly on the LED display before showing "0.00".
- Use the plus **(7)** and minus **(5)** buttons to set the time of day that you want the oven to switch off at.
- The automatic cooking symbol and the time of day will appear on the LED display.
- The appliance will automatically calculate what time of day it needs to switch the oven on at, so that it runs for the cooking time that you set.
- When the oven switches on, the oven in use symbol **(2)** will appear on the LED display, as well as the automatic cooking symbol.
- At the end of the cooking time, an audible signal will sound and the automatic cooking symbol will flash on the LED display.

- To reset the oven and cancel the audible alarm, press the programme button until the oven in use symbol appears on the LED display and the automatic cooking symbol goes out.
- **IMPORTANT:** *If you have not turned the oven function selector knob and thermostat control knob to their OFF positions, when you reset the oven it will continue to heat.*

Cancelling the semi-automatic and automatic function

- Press and hold down the minus **(5)** and plus **(7)** button simultaneously, until the automatic cooking symbol **(1)** goes out and the oven in use symbol **(2)** is lit.
- **IMPORTANT:** *If you do not turn the oven function selector knob and thermostat control knob to their OFF positions, when you reset the timer function, it will continue to heat.*

Cancelling the minute minder function

- Press and hold down the programme button **(6)** until the decimal point starts to flash to enter programming mode.
- Press and hold down the minus **(5)** and plus **(7)** buttons simultaneously.
- The minute minder symbol **(4)** will go out.
- **IMPORTANT:** *If you do not turn the oven function selector knob and thermostat control knob to their OFF positions, when you reset the timer function, it will continue to heat.*

Adjusting the volume of the audible signal

The volume of the audible signal has 3 levels, low, medium and high. To adjust the volume, you should proceed as follows: -

- **IMPORTANT:** *The oven timer/programmer must not be in any form of countdown mode and the oven in use symbol **(2)** must be lit.*
- Press and hold down the minus **(5)** and plus **(7)** buttons simultaneously until the decimal point starts to flash.
- Press the programme button **(6)** and the LED display will show "ton" followed by a number (e.g. "ton1"). 1 is the loudest volume, 2 is the middle volume and 3 is the quietest volume.

- Use the minus button to select the volume level that you desire. Press the programme button to confirm.

Changing the time of day

- **IMPORTANT:** The oven timer/programme must not be in any form of countdown mode and the oven in use symbol (2) must be lit.
- Press and hold down the minus (5) and plus (7) buttons simultaneously until the decimal point starts to flash.
- Release these buttons and then use the minus and plus buttons to alter the time of day.

Selecting a cooking function and temperature



IMPORTANT: Before attempting to select an oven function for the first time, you must set the time of day.

Selecting a top oven function and temperature

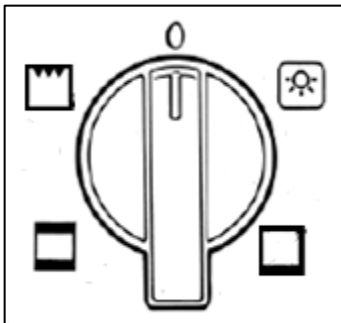

- The top oven control knob can be used to select the particular mode of cooking that you require, as well as the temperature.
- The appliance will utilise different elements within the oven cavity, depending on the oven function that you select.
- When a function is selected, the main oven power indicator light will come on.

Top oven functions



OVEN LIGHT: Separate light control which allows the light to be switched on, even when the oven is switched off.



LOWER ELEMENT ONLY: This method of cooking uses the lower element to direct heat upward to the food. This function is suitable for slow-cooking recipes or for warming up meals.

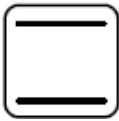

CONVENTIONAL OVEN (top and lower element): This method of cooking provides traditional cooking, with heat from the top and lower elements. This function is suitable for roasting and baking on one shelf only.



FULL GRILL: This method of cooking utilises the inner and outer parts of the top element, which directs heat downwards onto the food. This function is suitable for grilling medium or large portions of sausages, bacon, steaks, fish etc.

Selecting a main oven function and temperature

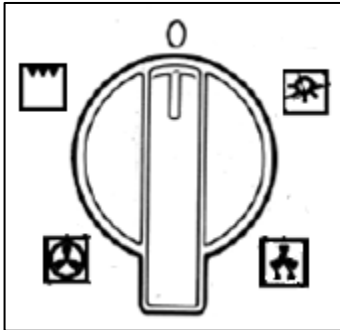

- The main oven control knob can be used to select the particular mode of cooking that you require, as well as the temperature.
- The appliance will utilise different elements within the oven cavity, depending on the oven function that you select.
- When a function is selected, the main oven power indicator light will come on.

Main oven functions



OVEN LIGHT: Separate light control which allows the light to be switched on, even when the oven is switched off.



DEFROST MODE: The fan runs without heat to reduce the defrosting time of frozen foods. The time required to defrost the food will depend on the room temperature, the quantity and type of food. Always check food packaging for the defrosting instructions.



FAN OVEN: This method of cooking uses the circular element while the heat is distributed by the fan. This results in a faster and more economical cooking process. The fan oven allows food to be cooked simultaneously on different shelves, preventing the transmission of smells and tastes from one dish onto another.



FULL GRILL: This method of cooking utilises the inner and outer parts of the top element, which directs heat downwards onto the food. This function is suitable for grilling medium or large portions of sausages, bacon, steaks, fish etc.

Oven operating lights (main and top oven)

This light will come on to indicate that the oven's heating elements are in operation. The light will switch off when the temperature set has been reached. It will cycle on and off throughout the cooking time.

You should not place food inside the cavity, until the correct cooking temperature has been reached.

Using the grill

IMPORTANT: The oven door should always be closed when using the grill function.

- Move the safety shelf to the first or second shelf position from the top.
- Select the grill function and preheat the grill for 5 minutes before introducing food into the cavity.
- Place the food in the middle of the grill pan and position the pan so the food is near but not touching the top element.
- ***DO NOT*** line the grill pan with aluminium foil or wrap food items with foil before placing them under the grill. The high reflectivity of the foil can damage the grill elements.
- When fitting the handle, hook the handle over the edge of the grill pan and through the wire rack at a central point along the grill pan edge, as shown in the drawing below. Lower the handle fully down to secure.

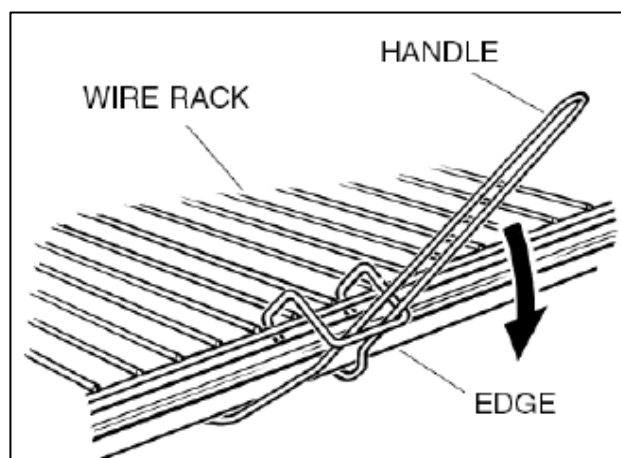

IMPORTANT: The grill should only be used for a maximum of 30 minutes at a time.

Cooking guidelines

- Please refer to the information given on food packaging for guidance on cooking temperatures and times. Once familiar with the performance of your appliance, temperatures and times can be varied to suit personal preference.
- When using the fan oven function you should follow the information given on the food packaging for this particular mode of cooking.
- You should pre-heat the oven and not place food inside of it until the oven operating light has gone off. You can choose not to pre-heat when using the fan oven mode; however you should extend the cooking time given on the food packaging by at least ten minutes.
- ***IMPORTANT:*** *You should ALWAYS pre-heat the oven if you are baking.*
- If there is no guidance given on the food packaging specifically for cooking in fan oven mode, you can generally reduce the cooking time and temperature by 10% from the information given for conventional oven cooking.
- Make sure that frozen foods are thoroughly thawed before cooking, unless the instructions on the food packaging advise that you can “cook from frozen”.
- Before cooking, check that any accessories that are not required are removed from the oven.
- Place cooking trays in the centre of the oven and leave gaps between the trays to allow air to circulate.
- Try to open the door as little as possible to view the dishes.
- The oven light will remain on during cooking.

Warnings

- Keep the oven door closed when using **any** of the cooking functions, ***including*** all grill functions.
- Do not use aluminium foil to cover the enamelled baking tray or heat items wrapped in aluminium foil under the grill. The high reflectivity of the foil could potentially damage the grill element.
- You should also never line the base of your oven with aluminium foil.

- During cooking, never place pans or cookware directly onto the bottom of your oven. They should always be placed on the shelves provided.
- The grill heating element and other internal components of the oven become extremely hot during operation, avoid touching them inadvertently when handling the food which you are grilling.
- **Important:** *Be careful when opening the door, to avoid contact with hot parts of the oven and steam.*
- **Warning:** *Accessible parts may become hot during use. Young children should be kept well away from the oven when it is in use.*
- The enamelled baking tray handle should only be used to reposition the tray and **NOT** for removing it from the oven cavity. When removing the enamelled baking tray, you should **ALWAYS** use an oven glove.
- The enamelled baking tray handle should not be left in position when the appliance is switched on.

Cleaning and maintenance



Cleaning operations must only be carried out when the oven is cool.

The appliance should be disconnected from your mains supply before commencing any cleaning process.

- The oven should be thoroughly cleaned before it is operated for the first time and after each use. This will avoid residual food stuffs becoming baked on the oven cavity. After residues have been baked on several times, they are far more difficult to remove.
- **Never** clean the oven surfaces by steam cleaning.
- The oven cavity should only be cleaned with warm soapy water, using either a sponge or soft cloth. No abrasive cleaners should be used.
- Any stains that may appear on the bottom of the oven will have originated from food splashes or spilt food, these splashes occur during the cooking process. These could possibly be a result of the food being cooked at an excessively high temperature or being placed in cookware that is too small.

- You should make sure that the cooking temperature that is selected is appropriate for the food that you are cooking. You should also ensure that the food is placed in an adequately sized dish and use the enamelled baking tray where appropriate.
- Outer parts of the oven should only be cleaned with warm soapy water, using either a sponge or soft cloth. No abrasive cleaners should be used.
- We would recommend that an appropriate stainless steel cleaner and polish is regularly used on the stainless steel surfaces of this appliance (BO796.5SS only)
- If you use any form of oven cleaner on your appliance, then you must check with the manufacturer of the cleaner that it is suitable for use on your appliance.
- ***Any damage that is caused to the appliance by a cleaning product will not be fixed by Baumatic free of charge, even if the appliance is within the guarantee period.***

Removing the side racks



To properly clean the oven cavity, it is necessary to remove all of the oven furniture, including the side racks. To remove the side racks you should follow the instructions shown in the picture on the previous page.

Replacing the oven bulbs (both ovens)



IMPORTANT: *The oven must be disconnected from your mains supply before you attempt to either remove or replace the oven bulbs. Ensure that the oven is cool before touching the interior surfaces.*

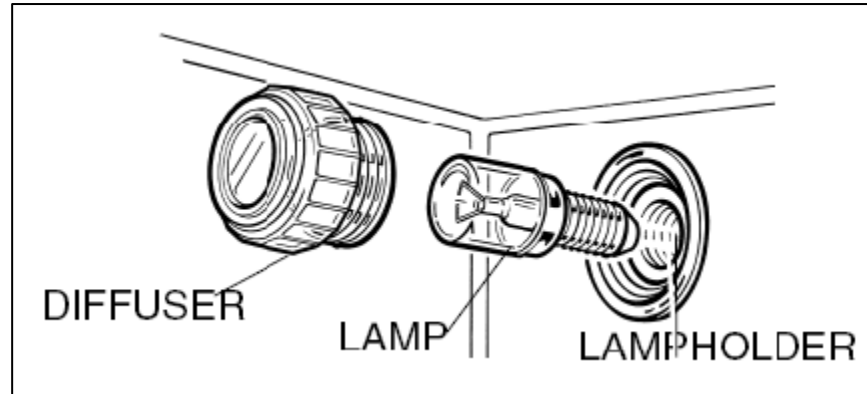

- Remove all oven shelves, the enamelled baking tray and the side racks.
- Unscrew and remove the diffuser from the lamp holder.
- Unscrew the lamp from the lamp holder and replace the bulb with a 25 W/300°C, screw type pygmy.
- **Do not** use any other type of bulb.
- Replace the diffuser by screwing it back into its original position.

Removing the oven doors for cleaning

To facilitate the cleaning of the inside of the oven and the outer frame of the oven, the door can be removed as follows: -

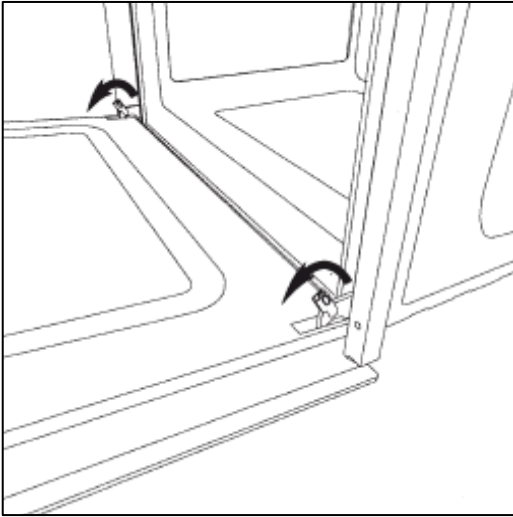

- The hinges have two movable bolts on them.
- If you raise both of the movable bolts, then the hinges are released from the oven housing.
- You should grip the sides of the door at the centre and then incline it slightly towards the oven cavity and then pull the door gently away from the oven cavity.

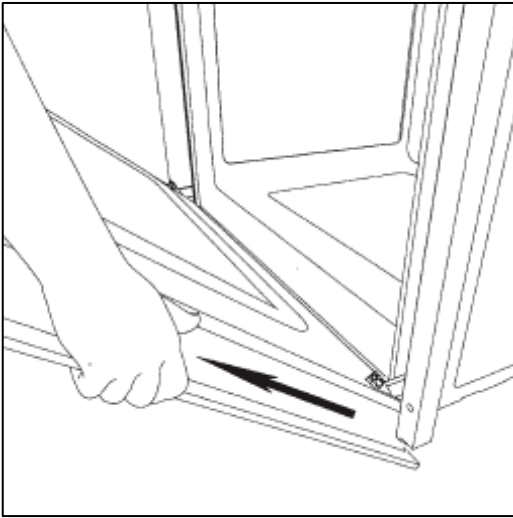

- **IMPORTANT:** You should make sure that the door is supported at all times and that you place the door on some padded material whilst cleaning it.
- The oven door and door glass should only be cleaned using a damp cloth and a small amount of detergent. The cloth **MUST NOT** have come into contact with any form of cleaning product or chemical previously.

- To refit the door you should slide the hinges back into their slots and open the door fully.
- **IMPORTANT:** The movable bolts must be closed back into their original positions before closing the door.



- **Take care not to dislodge the hinge locking system when removing the door, as the hinge mechanism has a strong spring.**
- **Do not immerse the door in water at any time.**

IMPORTANT: Ensure that the oven door is cool before cleaning.

INSTALLATION



The installation must be carried out by a suitably qualified person, in accordance with the current version of the following.

- **UK Regulations and Safety Standards or their European Norm Replacements.**
- **Building Regulations** (issued by the Department of the Environment).
- **Building Standards** (issued by the Scottish Development Department).
- **IEE Wiring Regulations.**
- **Electricity At Work Regulations.**

Before connecting the appliance, make sure that the supply voltage marked on the rating plate corresponds with your mains supply voltage.

WARNING: THIS APPLIANCE MUST BE EARTHED.

- This appliance should be wired into a 30A double pole switched fused spur outlet, having 3 mm contact separation and placed in an easily accessible position adjacent to the appliance. The spur outlet must still be accessible even when your oven is located in its housing.

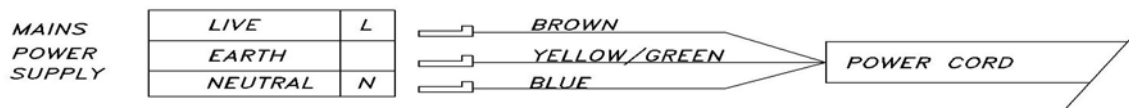

- To connect the oven power cord, loosen and remove the cover on the terminal block, in order to gain access to the contacts inside. Make the connection, securing the cord in place with the cable clamp provided and then immediately close the terminal block cover again.
- If you have to change the oven power cord, the earthing (yellow/green) conductor must always be 10 mm longer than the line conductors.
- Care must be taken to ensure that the temperature of the mains supply cable does not exceed 50°C.
- If the mains supply cable is damaged, then it must be replaced by an appropriate replacement.
- Cable type: H05 RRF 3 core x 2.5 mm²

Connecting the mains supply cable

- The mains terminal block is located on the rear of the oven and the terminals are accessible by removing the terminal block cover. You should remove the cover screw to access this.
- The cable connections must be made in accordance with the diagram below: -

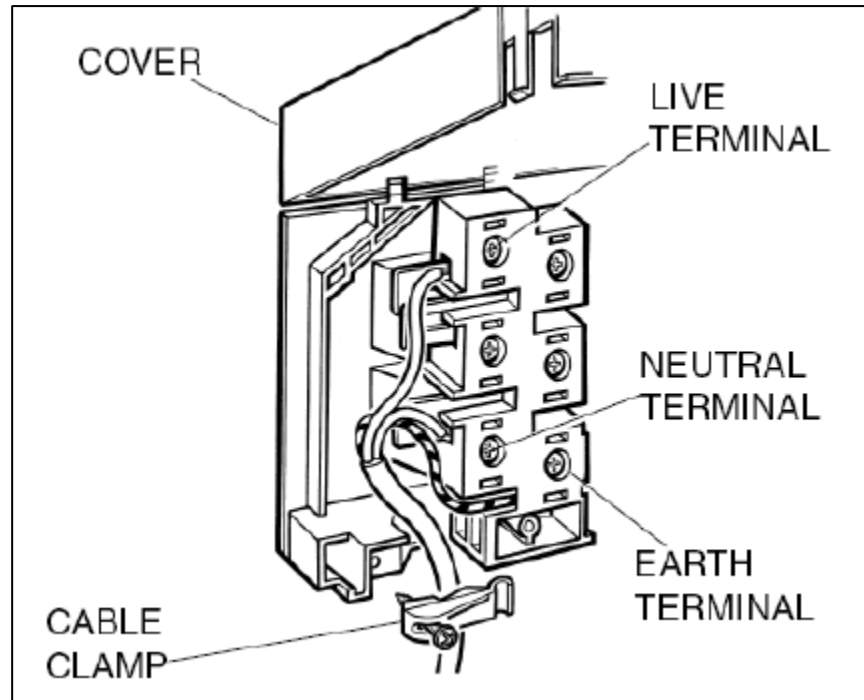

- The brass links must be positioned as marked in the diagram above and once established ALL terminal screws must be tightened down firmly.

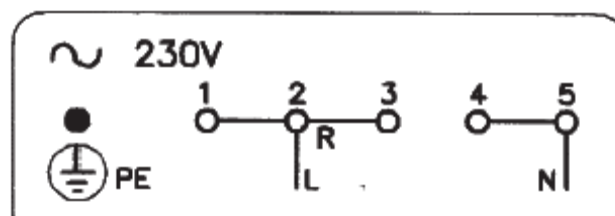

- ***If when the oven is first switched on, it does not function correctly, you should recheck that the terminal screws are all fully tightened between the links. This should be done before contacting the Customer Care Department.***
- ***IMPORTANT:*** The appliance must NOT be connected to the mains supply by means of a 13A plug and socket.

- The cable can be looped if necessary, but make sure that is not kinked or trapped when the oven is in position. Care must be taken to avoid the cable being in contact with hot parts of the appliance.

Replacing the mains supply cable

If the mains supply cable is damaged, then it must be replaced with a suitable replacement.

The mains supply cable should be replaced in accordance with the following instructions: -

- ***Switch the appliance off at the socket.***
- Open the terminal block on the back of the oven.
- Unscrew the terminal screws fixing the cable.
- Replace the cable with one of the same length and in accordance with the specification given on page 26.
- The “green-yellow” earth wire must be connected to the terminal marked \perp . It must be about 10 mm longer than the live and neutral wires.
- The “blue” neutral wire must be connected to the terminal marked with letter (N) - the live wire must be connected to the terminal marked with letter (L).

Built-under installation

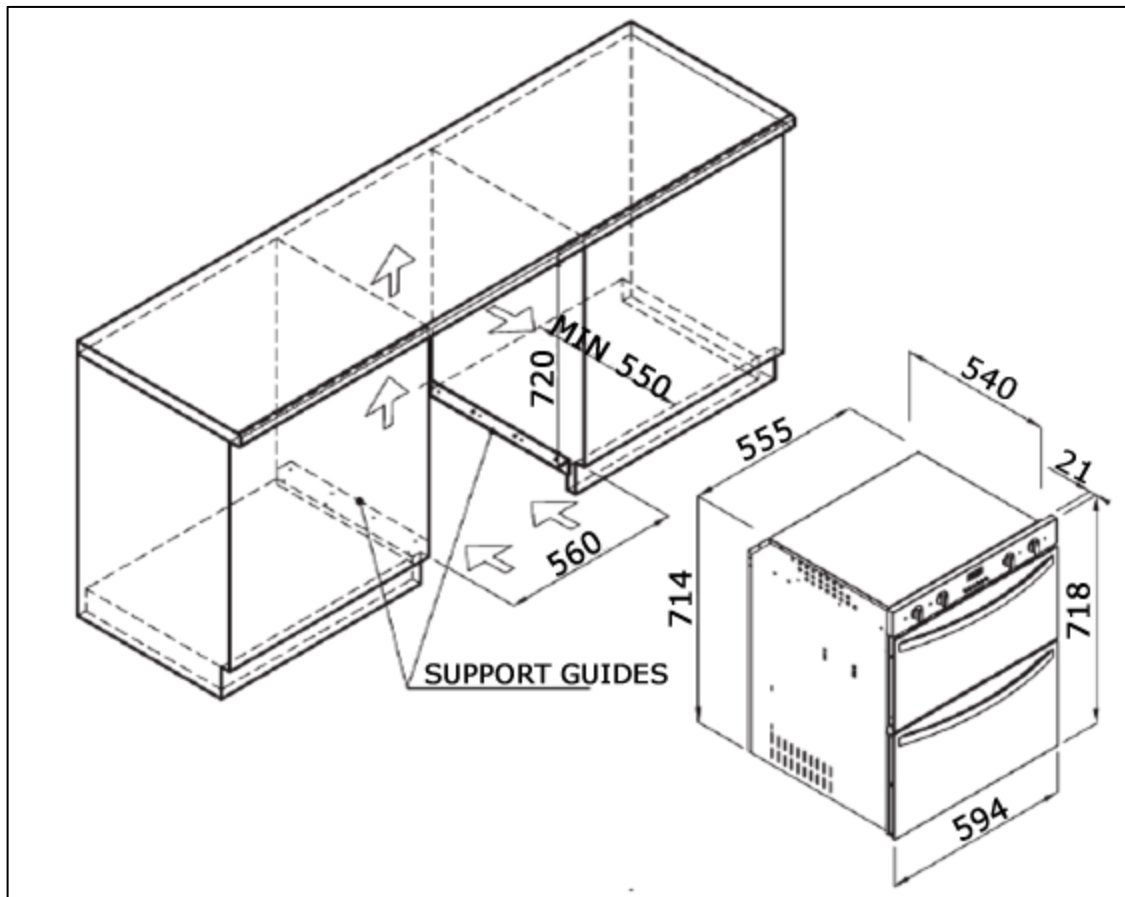

Positioning the appliance

- Do not install your oven too close to a fridge or boiler.
- Ensure that the aperture that you will be fitting the oven into is of the size given in the above diagram.
- The oven must be fitted into the aperture using the support guides supplied.
- Ensure that the rear panel of the furniture unit has been removed.
- The side panels of the kitchen unit(s) must be full length and go all the way down to the floor.
- If your kitchen units are on legs, then you must fit full length side panels to the side of the units that the support brackets will screw into, **before** commencing the installation process.

Ventilation requirements

- Ensure that the aperture that you will be fitting the oven into is of the size given in the diagram. This will provide a gap at the back of the oven to allow air to circulate as shown in the drawing on the previous page.
- There should also be a small gap between the top of the oven and the bottom of the work surface which the oven is built under.



IMPORTANT: *The ventilation requirements shown MUST be followed; otherwise the oven may not operate correctly.*

My appliance isn't working correctly

- ***The oven isn't coming on.***
 - * Check that you have selected a cooking function and a cooking temperature.
 - * Check that the automatic cooking symbol **(1)** isn't lit on the LED display.
- ***There appears to be no power to the oven and grill.***
 - * Check that the appliance has been connected to the electrical mains supply correctly.
 - * Check that the mains fuses are in working order.
- ***The grill function works but the main oven does not.***
 - * Check that you have selected the correct cooking function.
- ***The grill and top oven element is not working, or cuts out for long periods of time during use.***
 - * Allow the oven to cool for approximately 2 hours. Once cool, check whether the appliance is again working properly.

- ***My food is not cooking properly.***
 - * Ensure that you are selecting the correct temperature and the correct cooking function for the food that you are cooking. It may be appropriate to adjust your cooking temperature by plus or minus 10°C, to achieve the best cooking results.

- ***My food is not cooking evenly.***
 - * Check that the oven has been installed correctly and is level.
 - * Check that the correct temperatures and shelf positions are being used.

- ***The oven light is not working.***
 - * Refer to page 24 and follow the “Replacing the oven bulb” section.

- ***I am getting condensation in my oven.***
 - * Steam and condensation is a natural by product of cooking any food with high water content, such as frozen food, chicken etc.
 - * You may get condensation in the oven cavity and forming between the oven door glasses. This is not necessarily a sign that the oven is not working correctly.
 - * Do not leave food in the oven to cool after it has been cooked and the oven has been switched off.
 - * Use a covered container, where practical, when cooking to reduce the amount of condensation that forms.



IMPORTANT: If your appliance appears not to be operating correctly, then you should disconnect it from your mains supply and then contact Baumatic Customer Care on telephone number (0118) 933 6911.

DO NOT ATTEMPT TO REPAIR THE APPLIANCE YOURSELF.

Please note that if an engineer is asked to attend whilst the product is under guarantee and finds that the problem is not the result of an appliance fault, then you may be liable for the cost of the call out charge.

The appliance must be accessible for the engineer to perform any necessary repair. If your appliance is installed in such a way that an engineer is concerned that damage will be caused to the appliance or your kitchen, then he will not complete a repair.

This includes situations where appliances have been tiled in, sealed in with sealant, have wooden obstructions placed in front of the appliance, like plinths. Or any installation other than the one specified by Baumatic Ltd. has been completed.

Please refer to the conditions of guarantee that appear on the warranty card that you receive with the appliance.

IMPORTANT: Baumatic Ltd. operates a policy of continuous improvement and reserves the right to adjust and modify its products without prior notification.

Baumatic Consumables

- **BC001** Degreaser for Dishwashers (200 g)
- **BC002** Descaler for Washing Machines and Dishwashers (200 g)
- **BC003** Ceramic Hob Cleaner (250 ml)
- **BC004** Oven Cleaner (250 ml)
- **BC005** Stainless Steel Cleaner and Protector (250 ml)
- **BC007** E-Cloth – General Purpose Cloth
- **BC008** Microwave Cover

To order a Baumatic consumable product please call 0123 5437 244 and quote the product code. You can also order online from eshop.baumatic.co.uk



United Kingdom

Baumatic Ltd.,
Baumatic Buildings,
6 Bennet Road,
Reading, Berkshire
RG2 0QX
United Kingdom

Sales Telephone

(0118) 933 6900

Sales Fax

(0118) 931 0035

Customer Care Telephone

(0118) 933 6911

Customer Care Fax

(0118) 986 9124

Spares Telephone

(01235) 437244

Advice Line Telephone

(0118) 933 6933

E-mail:

sales@baumatic.co.uk
customercare@baumatic.co.uk
spares@baumatic.co.uk
technical@baumatic.co.uk

Website:

www.baumatic.co.uk

Facebook:

www.facebook.com/baumatic.uk

Republic of Ireland

Service Telephone

1-890 812 724

Spares Telephone

091 756 771

Czech Republic

Baumatic CR spol s.r.o.
Lípová 665
460 01 Liberec 4
Czech Republic

+420 483 577 200

www.baumatic.cz

Slovakia

Baumatic Slovakia, s.r.o.
Panenská 34
811 03 Bratislava - Staré Mesto
Slovakia

+421 255 640 618

www.baumatic.sk

Germany

Baumatic GmbH
Bachstr.10-12
D-32 257 Bünde
Deutschland

+49 (0) 5223 99408 0

www.baumatic.de

Italy

Baumatic Italia S.R.L.
Via Galvani N.3
35011 Campodarsego (PD)

+3904 9920 2297

www.baumatic.it

Holland

Baumatic Benelux B.V.
Dukdalfweg 15d
1332 BH ALMERE
Nederland

+31(0)36 549 1553

www.baumatic.nl

